

# INSTALLATION RECOMMENDATION

## HYDRONIC S3 – D 5 E IN THE FORD CONNECT ECOBLUE

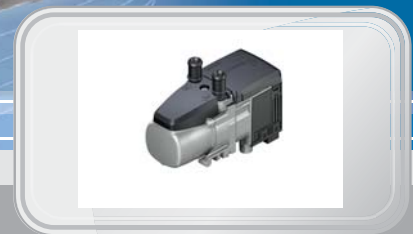

**THIS INSTALLATION RECOMMENDATION APPLIES TO VEHICLES FROM MODEL YEAR 2022 WITH THE FOLLOWING MOTORISATION:**

2.0 | EcoBlue / 75 kW - 102 HP (HSN: 8566 / BVW, BVX)

2.0 | EcoBlue / 90 kW - 122 HP (HSN: 8566 / BVY, BVZ)

# CONTENTS

CHAPTER	CHAPTER DESCRIPTION	PAGE
1	Introduction	3-5
2	Preliminary assembly	6-8
3	Installation	9-27
4	After installation	28-29
5	Parts overview	30
	Leaflet for the Customer	31

This installation recommendation documents the installation of the Hydronic S3 heater in a vehicle from model year 2022 with the following equipment:

- **Automatic aircon**
- **Fog lamp**
- **6-gear manual transmission or 7-gear automatic transmission**

**The following have not been checked:**

- **Manual aircon**

## PLEASE NOTE!

This installation recommendation is valid for the above mentioned vehicle to the exclusion of all liability claims. Deviating model years and/or deviating equipment may result in modifications to this installation recommendation. It is therefore mandatory to check the feasibility of installing the heater in the vehicle before starting work. All liability claims resulting from modifications to the vehicle are excluded.

Installation time: approx. 7 hours

# 1 INTRODUCTION

## SPECIAL TEXT FORMATS, PRESENTATIONS AND PICTURE SYMBOLS

In this installation recommendation, special text formats and picture symbols are used to emphasise different contents. Please refer to the following examples for their meanings and appropriate action.

### SPECIAL TEXT FORMATS AND PRESENTATIONS

- This dot (▪) denotes a list, which is started by a heading.
  - If an indented dash (–) follows a “dot”, this list is a sub-section of the black dot.

### PICTURE SYMBOLS



#### **DANGER!**

This information points out a potential serious or fatal danger. Ignoring this information can result in severe injuries.

- ➔ This arrow indicates the appropriate precaution to take to avert the danger.



#### **CAUTION!**

This information points out a dangerous situation for a person and / or the product. Ignoring this information can result in injuries to people and / or damage to equipment.

- ➔ This arrow indicates the appropriate precaution to take to avert the danger.



#### **PLEASE NOTE!**

These remarks contain recommendations for use and useful tips for the operation, installation and repair of the heater.

## SAFETY INSTRUCTIONS FOR INSTALLATION AND REPAIR



#### **DANGER!**

Improper installation or repair of Eberspächer heaters can cause a fire or result toxic exhaust entering the inside of the vehicle.

This can cause serious and even fatal risks.

- ➔ Only authorised and trained persons may install the heater according to the specifications in the technical documents or repair it using original spare parts.
- ➔ Installation and repairs by unauthorised and untrained persons, repairs using non-original spare parts and without the technical documents required for installation and repair are dangerous and therefore are not permitted.
- ➔ Installation according to this installation recommendation may only be carried out in conjunction with the respective unit-related technical description, installation instructions, operating instructions and maintenance instructions.

This document must be carefully read through before / during installation and repair and followed throughout. Particular attention is to be paid to the official regulations, the safety instructions and the general information.



#### **PLEASE NOTE!**

- The relevant rules of sound engineering practice and any information provided by the vehicle manufacturer are to be observed during the installation and repair.
- When carrying out electric welding on the vehicle, the positive cable at the battery should be disconnected and earthed to protect the control box.

## LIABILITY CLAIM / WARRANTY

Eberspächer does not accept any liability for defects and damage, which are due to installation or repair by unauthorised and untrained persons.

Compliance with the official regulations and the safety instructions is prerequisite for liability claims.

Failure to comply with the official regulations and safety instructions leads to exclusion of any liability of the heater manufacturer.

## ACCIDENT PREVENTION

General accident prevention regulations / health and safety regulations and the corresponding workshop, company and operating safety instructions are to be observed.

# 1 INTRODUCTION

## ADDITIONAL INFORMATION ON THE VALIDITY OF THE INSTALLATION RECOMMENDATION

The installation recommendation is valid for the vehicle with the engine and gearbox options listed in the following.

### ENGINE AND GEARBOX OPTIONS

Cubic capacity	kW / HP	Gearbox
2.0l EcoBlue	75 / 102	6S / 7EDC
2.0l EcoBlue	90 / 122	6S / 7EDC

6S = 6-speed manual gearbox

7A = 7-gear automatic gearbox

### PLEASE NOTE!

- The installation recommendation is not valid for right-hand drive vehicles.
- Vehicle models, engine types and feature options not listed in this installation recommendation, have not been tested. Installation according to this installation recommendation can still be possible.

## INITIAL STARTUP OF THE HEATER OR FUNCTIONAL TEST

- After installation or carrying out a repair on the heater, the coolant circuit and the whole fuel supply system must be carefully vented. Comply with the instructions issued by the vehicle manufacturer.
- Open all heating circuits before the trial run (set the temperature controller to "hot").
- During the heater trial run, all water and fuel connections must be checked for leaks and secure, tight fit.
- If faults occur while the heater is running, use a diagnostic unit to correct the cause of the fault.

## PARTS REQUIRED FOR INSTALLATION

QUANTITY	DESIGNATION	ORDER NO.
1	Hydronic S3 - D 5 E	25 2736 05 0000
1	Vehicle-specific installation kit	24 8000 39 0089

EasyStart control unit as chosen:

1	EasyStart Timer	22 1000 34 1500
1	EasyStart Web	22 1000 35 4000
1	EasyStart Remote+	22 1000 34 1700
1	EasyStart Remote	22 1000 34 8100

## SPECIAL TOOLS REQUIRED

- Necessary torque wrench
- Anti-corrosion agent
- Pliers for spring band clamps
- Tool for undoing the tank fitting
- Crimping tool
- Step drill

## TIGHTENING TORQUES

If no tightening torques are specified, tighten the screw connections according to the following table:

Part name	Tightening torques
Hex screw M6	10 <sup>+1</sup> Nm
Hex screw M8	20 <sup>+2</sup> Nm
Hex screw M10	45 <sup>+2</sup> Nm
Self-threading M6 x 16 Torx screw	11 <sup>+1</sup> Nm
Screw M4	3 <sup>+0.5</sup> Nm
Screw M5 x 10	5 <sup>+0.5</sup> Nm
Screw M5 x 18	6.5 <sup>+0.5</sup> Nm
Pipe clip for exhaust pipe	7 <sup>+1</sup> Nm
Hose clip for water hose	3 <sup>+0.5</sup> Nm
Hose clip for combustion air pipe	5 <sup>+0.5</sup> Nm
Hose clip for fuel pipe	1 <sup>+0.2</sup> Nm

# 1 INTRODUCTION

## INSTALLATION DRAWING

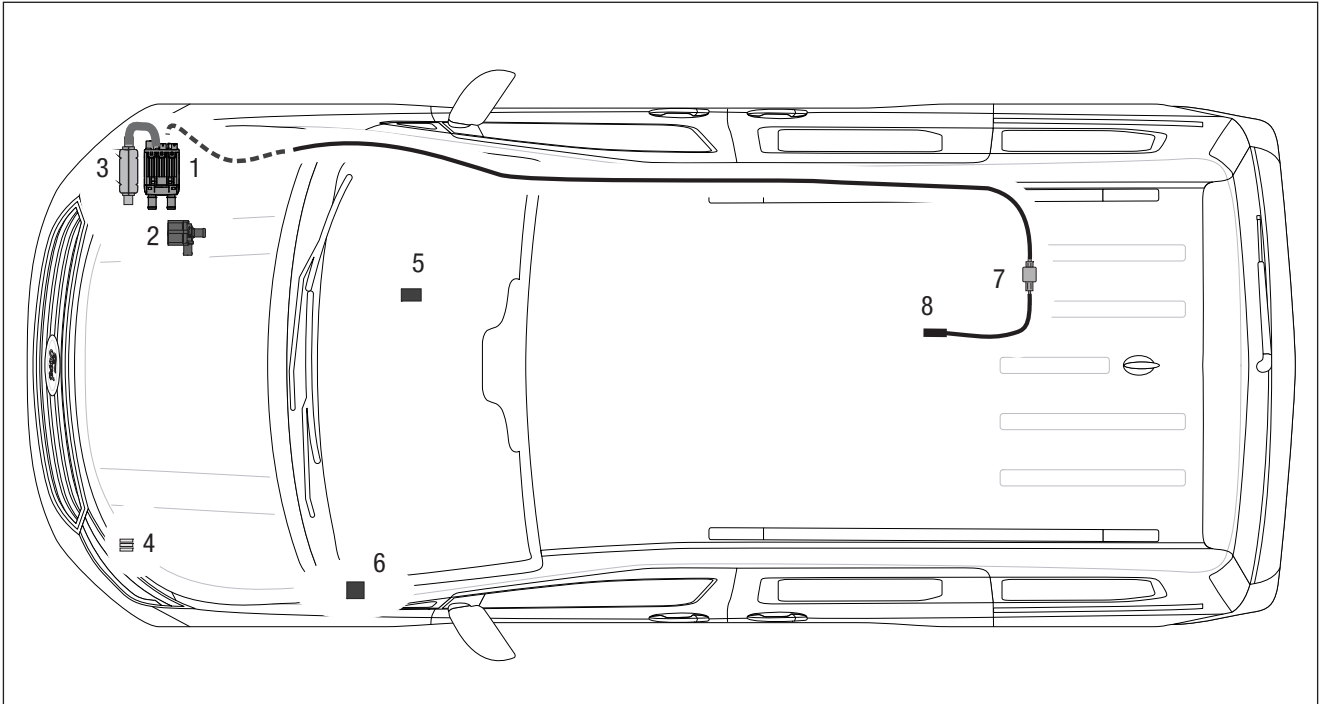

- 1 Heater Hydronic S3
- 2 Water pump
- 3 Exhaust silencer
- 4 Fuse holder
- 5 Smart IPCU
- 6 Control unit stationary part
- 7 Metering pump
- 8 Tank fitting adapter

## 2 PRELIMINARY ASSEMBLY

### PREPARATORY WORK ON THE VEHICLE

- Disconnect and remove battery
- Remove wiper pan
- Remove the sub-panelling of the glove compartment
- Remove the left-hand side panelling of the instrument panel
- Remove the right-hand front wheel and the wheel arch housing
- Remove sub-cowling
- Remove right-hand underbody shield
- Lower the fuel tank (by approx. 20 cm)
- Depressurise the cooling system
- Drain coolant into a clean container

### PREPARE HEATER

(see Figs. 1 and 2)

Mount the angled water connection socket to the heater as shown, see “Installation steps”.

Remove the duplicate nameplate from the heater.



Fig. 1

① Water connection socket mounted

### Installation steps

- Grease the O-ring (5) and insert in the groove at the connection socket.
- Fit the connection socket (3 or 4) in the cut-outs of the sensor cover (2). The collar of the connection socket is above the cover.
- Position the connection socket with the gearing in the sensor cover and fix accordingly.
- Fit the sensor cover on the heater with the connection socket pointing forwards.
- Press the connection socket completely into the corresponding holes on the heat exchanger.
- Adjust the direction for the angled connection socket:
  - Raise the sensor cover up to the collar of the connection socket
  - Turn the connection socket in the required direction
  - Push the sensor cover down and readjust the position of the connection socket so that the toothed edges engage again
- Fasten sensor cover with an M5 x 18 (1) screw (Torque 6.5<sup>+0.5</sup> Nm).

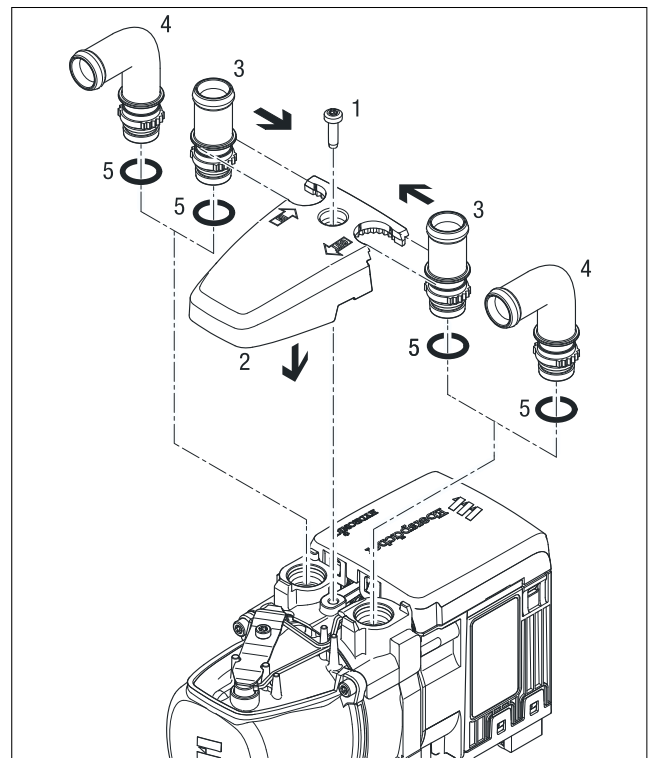

Fig. 2

- |                               |                            |
|-------------------------------|----------------------------|
| 1 M5 x 18 screw               | 4 Angled connection socket |
| 2 Sensor cover                | 5 O-ring                   |
| 3 Connection socket, straight |                            |

## 2 PRELIMINARY ASSEMBLY

### PREPARE THE WATER PUMP

(see Figs. 3 and 4)

Enlarge the existing hole in the water pump holder.

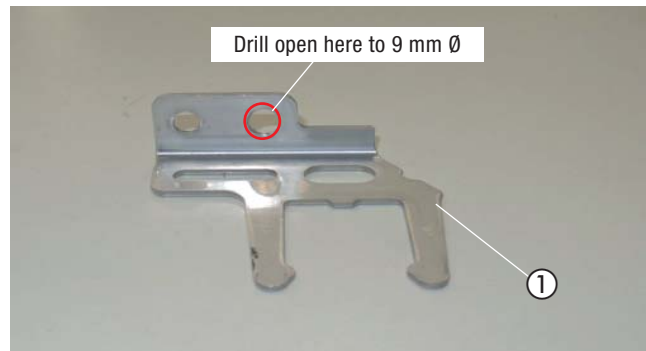

Fig. 3

① Water pump holder prepared

Insert the water pump in the holder as shown.



Fig. 4

① Water pump prepared

### PREPARE METERING PUMP

(see Fig. 5)

Fasten the L-bracket (22 1000 50 1400) with an M6 x 25 screw and a B6 body washer to the rubber bracket of the metering pump and align as shown.

Insert the metering pump in the rubber bracket.

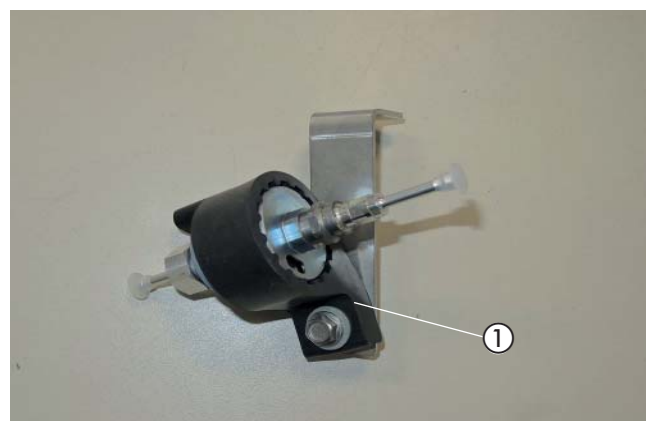

Fig. 5

① L-holder mounted to metering pump bracket

## 2 PRELIMINARY ASSEMBLY

### PREPARE FUSE HOLDER

(see Fig. 6)

Fasten the fuse block to the fuse block holder using two M4 expanding plastic rivets as shown.

Fasten the diagnostic connector to the connector holder and insert in the holder.

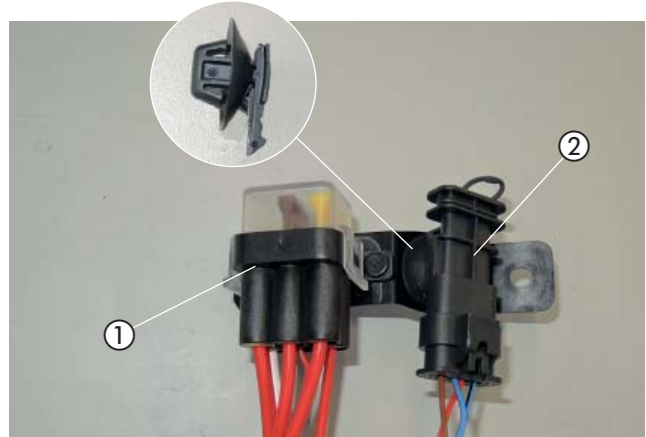

Fig. 6

- ① Fuse block mounted on the holder
- ② Connector holder with diagnostic connector

### IPCU MODULE CABLE LOOM

(see Fig. 7)

Prepare the IPCU module and the cable loom.

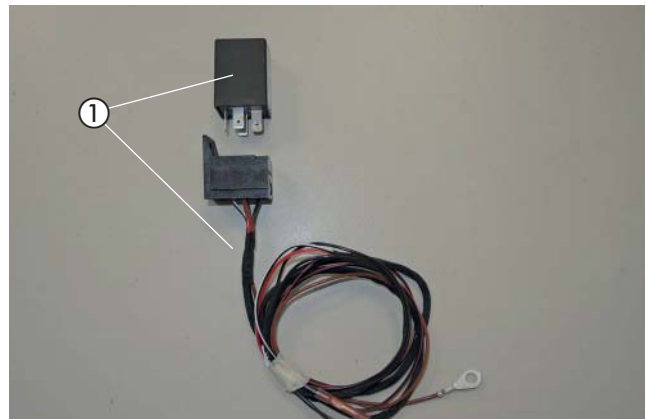

Fig. 7

- ① IPCU module and cable loom



### 3 INSTALLATION

#### PREPARE THE INSTALLATION POSITION

(see Figs. 8 and 9)

The installation position for the heater is on the outside of the right chassis beam.

Remove the plastic panelling on the outside of the right-hand chassis beam.



Fig. 8

① Remove plastic panelling

The front M8 stud bolt and the existing 12 mm Ø hole act as fastening points for the heater bracket.

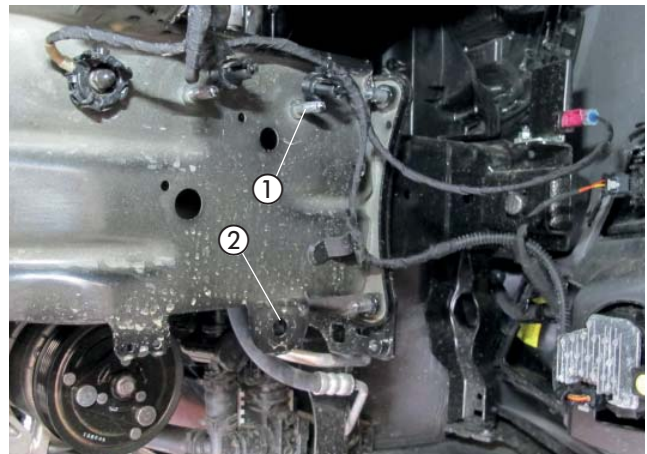
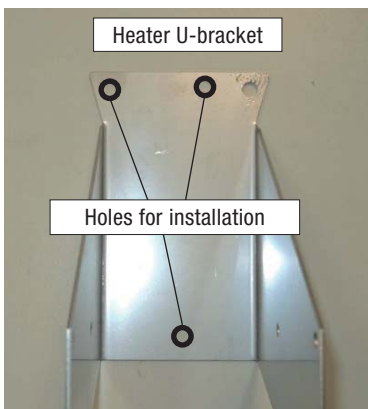

Fig. 9

① Front M8 stud bolt (1st fastening point)

② Existing 12 mm Ø hole (2nd fastening point)

#### MOUNT HEATER U-BRACKET

(see Fig. 10)

Fit the M14 body washer on the front M8 stud bolt and fasten the U-bracket with the vehicle's M8 nut and align horizontally (to match the lower fastening point).

Secure the U-bracket to the rear hole in the heater bracket using a self-tapping M6 x 19 screw.

Fasten the vehicle's cable loom to the M8 stud bolt again.

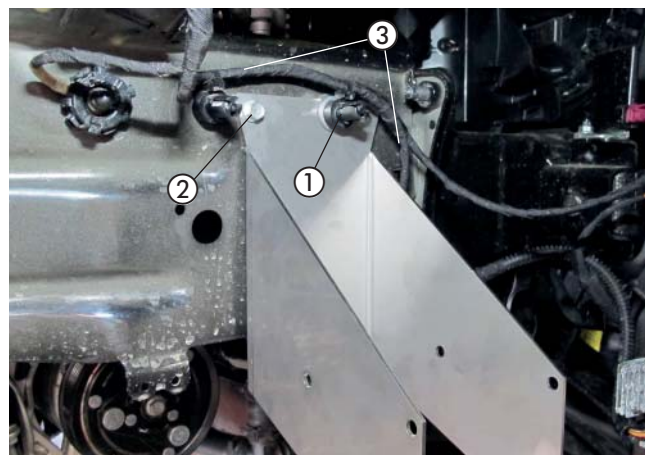

Fig. 10

① Vehicle's M8 nut

② Self-tapping M6 x 19 screw

③ Cable loom fastened

### 3 INSTALLATION

#### INSTALL WATER PUMP

(see Fig. 11)

Fasten the prepared water pump at the lower fastening point (3rd fastening point) using an M8 x 0 screw, a spacer sleeve and an M8 nut.

The discharge end points downwards and the intake end points to the rear.

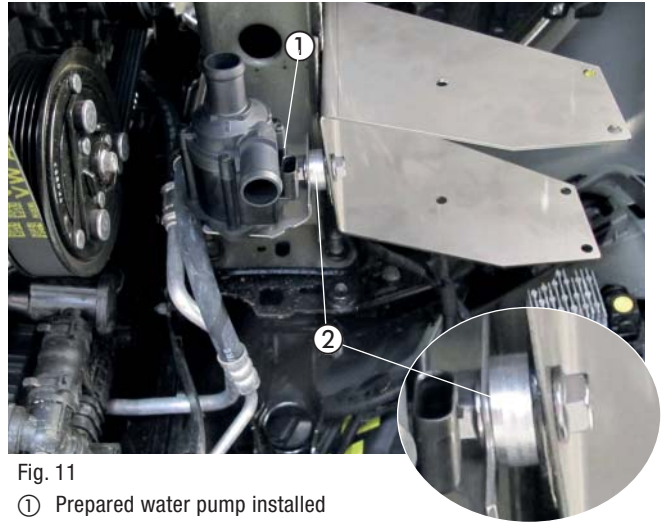

Fig. 11

- ① Prepared water pump installed
- ② Spacer sleeve

#### INSTALL EXHAUST SILENCER

(see Fig. 12)

Fasten the prepared exhaust silencer to the free threaded hole of the front crossbeam using an M8 x 16 screw and align as shown.



Fig. 12

- ① Exhaust silencer installed

#### INSTALL HEATER

(see Figs. 13 to 15)

Insert the heater in the heater bracket and fasten to the front of the heater bracket with two self-threading M6 x 16 screws.

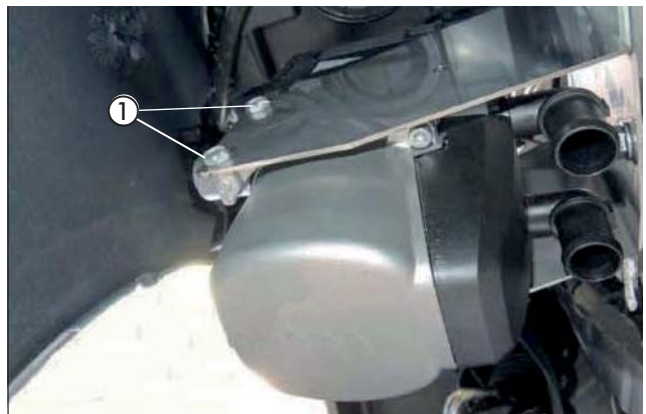

Fig. 13

- ① Heater mounted with 2 self-threading screws

### 3 INSTALLATION

Attach the heater to the rear side of the heater bracket using three M6 x 16 self-threading screws.

Use a clamp to connect the exhaust pipe to the exhaust connection of the heater.

Shape the exhaust pipe end as shown.

Position the rubber spacer at the hydraulic pipe.



#### CAUTION!

When laying the exhaust pipes, ensure they are at a sufficient distance from adjacent body components.

#### CONNECT AND LAY COMBUSTION AIR PIPE

(see Figs. 16 and 17)

Connect the combustion air pipe to the heater using a 16 - 25 mm Ø hose clip and lay it upwards into the right-hand wheel arch.



#### CAUTION!

Lay the combustion air silencer so that only clean, dry combustion air can be drawn in through the heater.

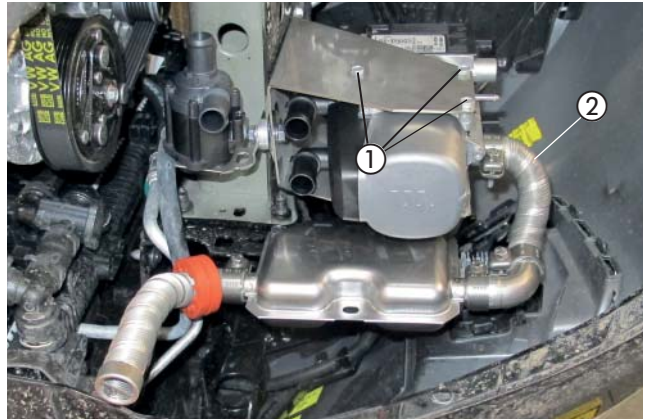

Fig. 14

- ① 3 x self-threading screws M6 x 16
- ② Exhaust pipe, connected



Fig. 15

- ① Rubber spacer



Fig. 16

- ① Rubber spacer



### 3 INSTALLATION

Lay the combustion air pipe into the protected area of the right-hand wheel arch and secure with cable ties.

**⚠ CAUTION!**

Lay the combustion air silencer so that only clean, dry combustion air can be drawn in through the heater.

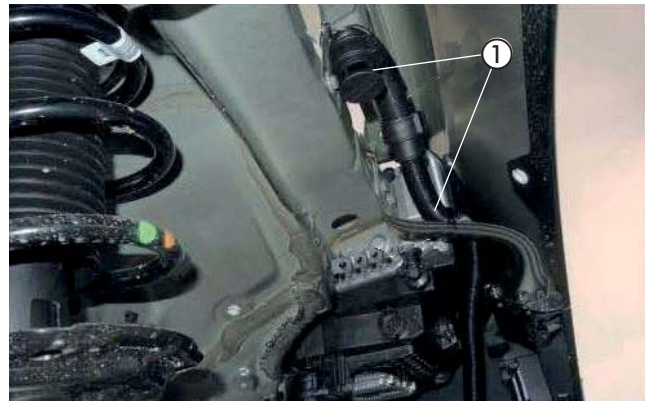

Fig. 17  
① Combustion air pipe laid

**PREPARE WATER HOSES**

(see Fig. 18)

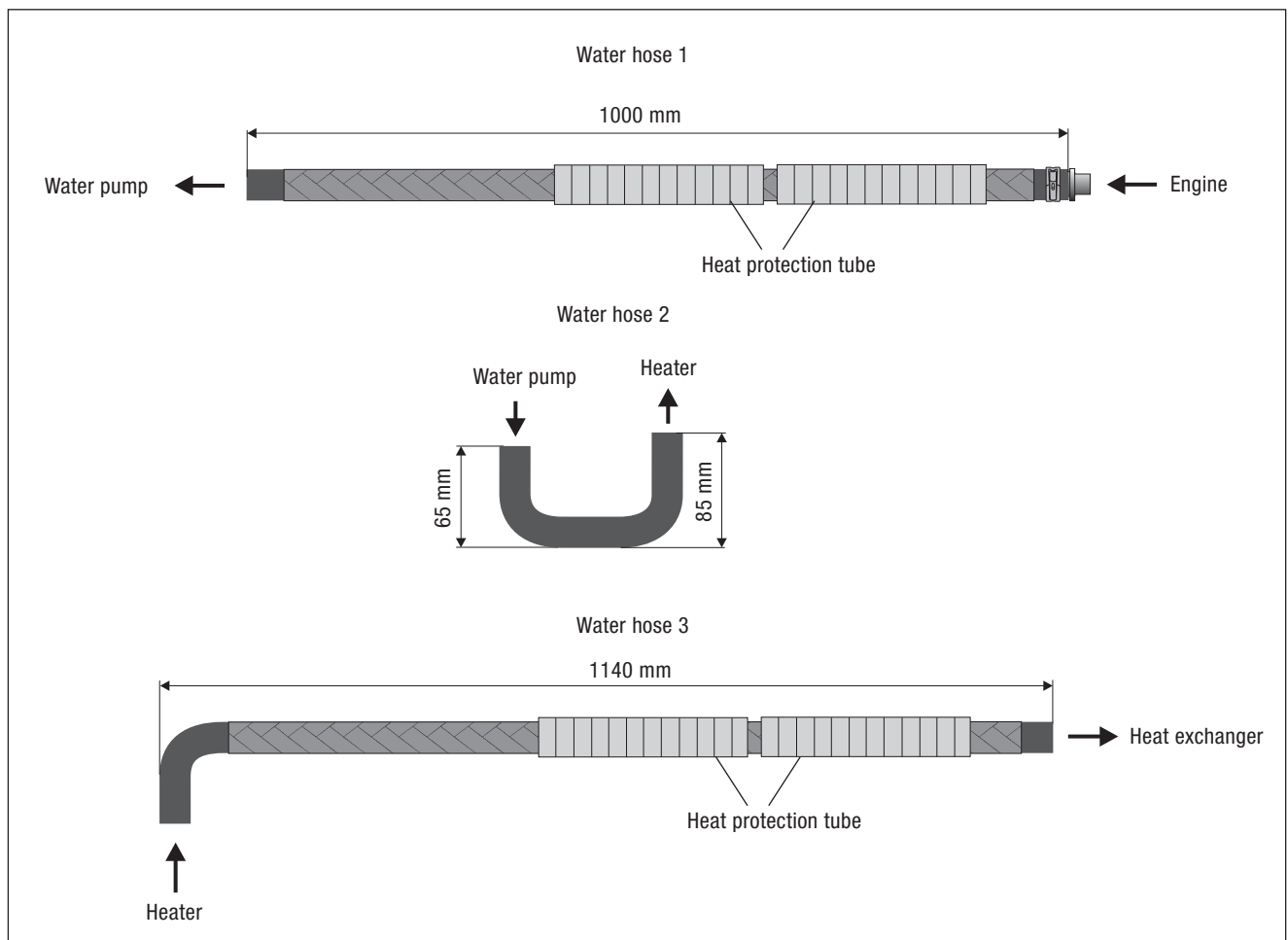

Fig. 18

### 3 INSTALLATION

#### PREPARE WATER FLOW HOSE

(see Figs. 19 to 21)

Remove the water flow hose from the engine to the heat exchanger (the upper water hose at the heat exchanger) by loosening the clamps.



Fig. 19

① Water flow hose

Cut the water flow hose from the engine to the heat exchanger (the upper water hose at the heat exchanger) according to the dimensions shown.

The marked hose piece (x) is no longer needed.

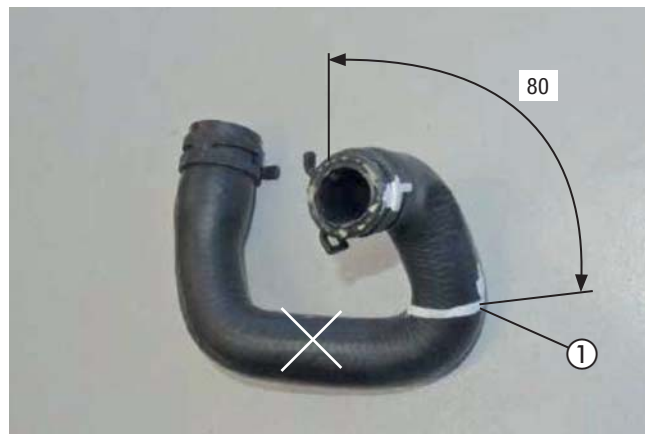

Fig. 20

① Water flow hose cutting point

Connect the cut off water flow hose to the adapter of water hose 1 (engine - water pump) and fasten with a 16-25 mm  $\emptyset$  hose clip.

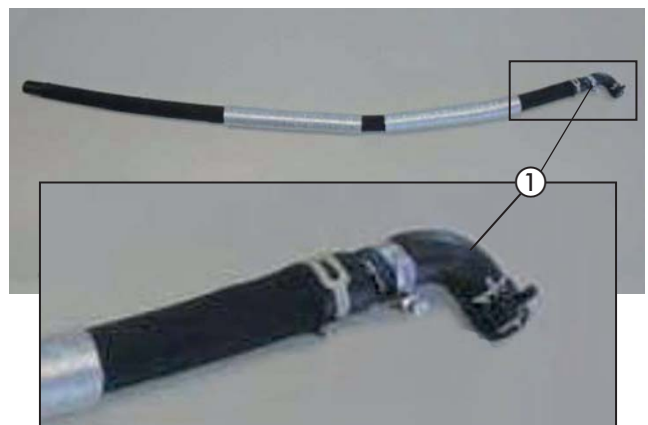

Fig. 21

① Cut off piece of water flow hose mounted to water hose 1

### 3 INSTALLATION

#### CONNECT AND LAY WATER HOSES

(see Figs. 22 to 34)

Connect water hose 2 to the water intake connection of the heater and to the discharge end of the water pump with a 20-32 mm  $\varnothing$  hose clip in each case.

Connect the cable loom of the water pump to the heater and to the water pump.



Fig. 22

① Water hose 2 connected

Insert an M8 blind rivet nut into the existing hole on the underside of the right-hand chassis beam.



Fig. 23

① M8 blind rivet nut inserted

Drill open the existing holes in the two 90° angle brackets (22.1000.50.6100) to 9 mm  $\varnothing$  as shown.

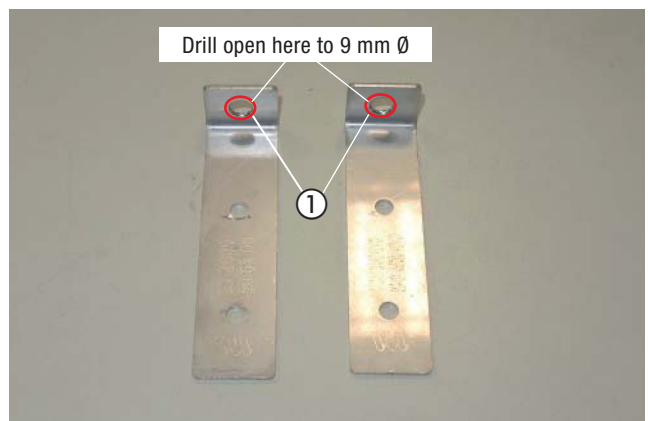

Fig. 24

① 2x existing holes drilled open to 9 mm  $\varnothing$

### 3 INSTALLATION

Fasten one 90° angle bracket (22.1000.50.61.00) to the inserted M8 blind rivet nut using an M8 x 16 screw.

Mount the second 90° angle bracket (22.1000.50.61.00) to the existing stud bolt using a Dm 5 plastic nut as shown.

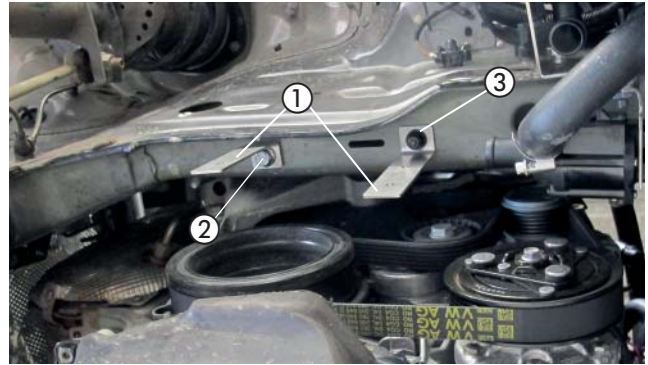

Fig. 25

- ① 2x 90° angle bracket (22.1000.50.61.00) mounted
- ② Screw M8 x 16
- ③ Plastic nut Dm5

Mount the 90° angle bracket (22.9000.52.0091) to the existing stud bolt on the inside of the right-hand chassis beam (next to the particulate filter) and align as shown.

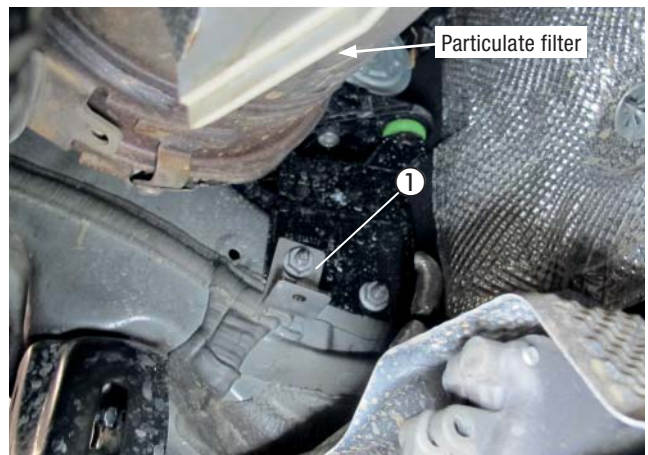

Fig. 26

- ① 90° angle bracket (22.9000.52.0091) mounted

Connect water hose 3 to the water outlet connection of the heater with a 26 mm Ø spring band clamp.

Connect water hose 1 to the intake end of the water pump with a 26 mm Ø spring band clamp.

Push a 30 mm Ø rubberised clip onto water hose 3 and fasten to the front mounted 90° angle bracket with an M6 x 16 screw.

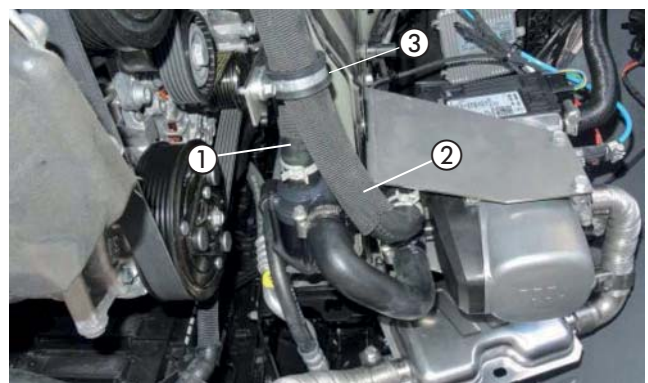

Fig. 27

- ① Water hose 1 connected
- ② Water hose 3 connected
- ③ 30 mm Ø rubberised clip



### 3 INSTALLATION

Push another 30 mm Ø rubberised clip onto water hose 3 and fasten to the rear mounted 90° angle bracket with an M6 x 16 screw.

Fasten water hoses 1 and 3 securely to one another using cable ties.



Fig. 28

① Water hose 3 secured with 30 mm Ø rubberised clip

Secure water hose 1 with a 30 mm Ø rubberised clip at the existing stud bolt on the inside of the chassis beam (next to the particulate filter) using an M6 nut.

Push a 30 mm Ø rubberised clip onto water hose 3 and fasten to the already mounted 90° angle bracket (next to the particulate filter) with an M6 x 16 screw.



Fig. 29

① Water hose 1 secured with 30 mm Ø rubberised clip

② Water hose 3 secured at 90° angle bracket

Fasten the water hose 1 with wide cable tape to the oblong hole of the ABS block bracket.

#### **⚠ CAUTION!**

When laying the water hoses, ensure they are at a distance of at least 1 cm from the particulate filter.



Fig. 30

① Water hose 1 secured with cable tape



### 3 INSTALLATION

Connect water hose 1 to the vehicle's spring band clamp at the engine connection.

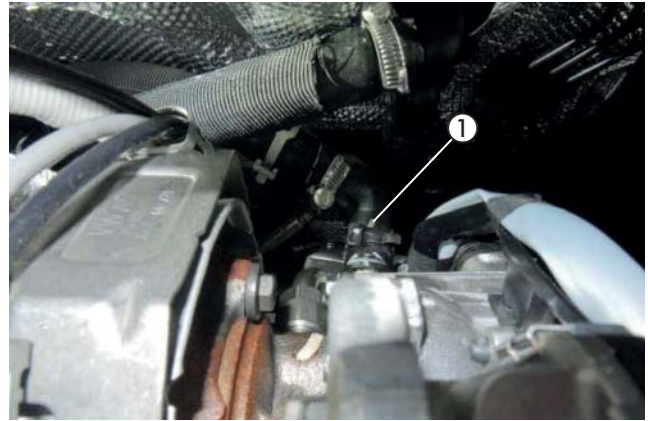

Fig. 31

① Water hose 1 connected to engine connection

Connect water hose 3 with a 20-32 mm Ø hose clip to the heat exchanger connection.



Fig. 32

① Water hose 3 connected to heat exchanger connection

Use cable tape to secure the water hoses 1 and 3 to each other.

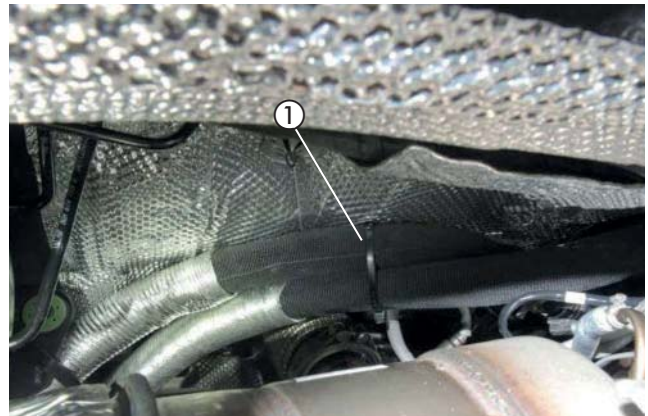

Fig. 33

① Water hoses 1 and 3 secured with cable tape

#### **⚠ CAUTION!**

Secure the hose connections to the vehicle's water hoses with screw clamps (20 - 32 mm Ø).

Protect the water hoses against chafing and use cable ties to secure in suitable positions.

### 3 INSTALLATION

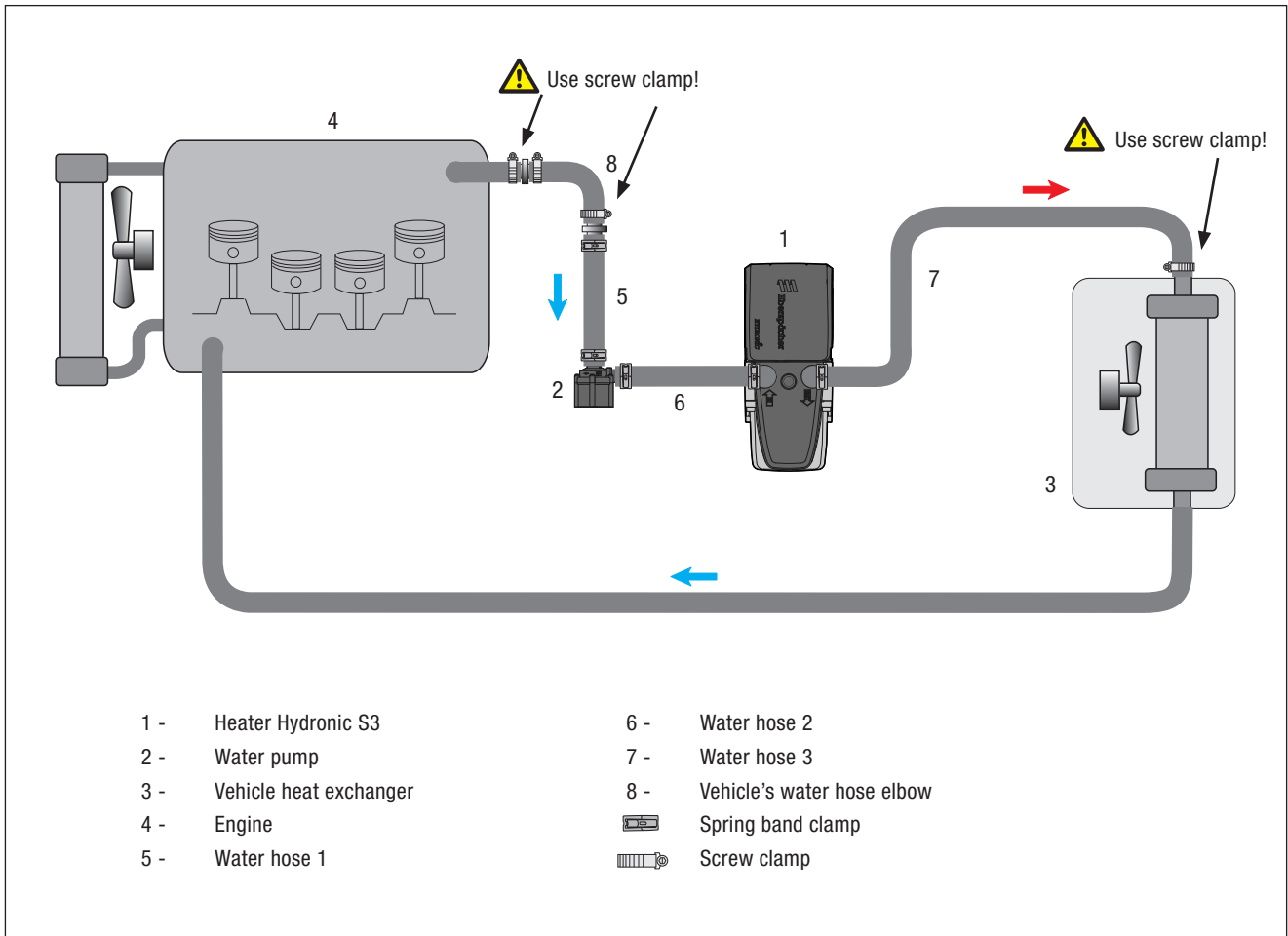

Fig. 34

## 3 INSTALLATION

### MAKE TANK CONNECTION

(see Figs. 35 to 37)

Prepare the fuel pipe intake line and fuel pipe delivery line.

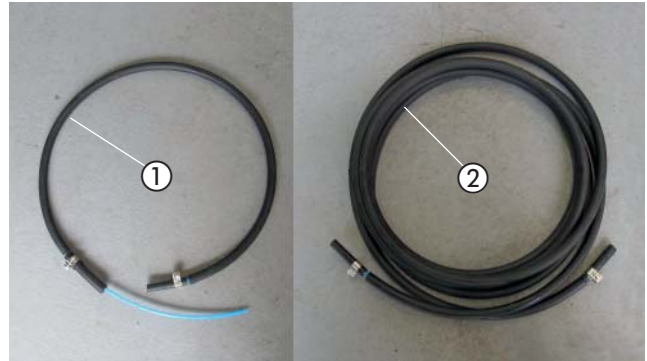

Fig. 35

- ① Fuel pipe intake line
- ② Fuel pipe delivery line

Lower the fuel tank.

Cut approx. 3 mm off the connection socket at the tank fitting.

#### CAUTION!

When opening the connection socket, ensure that no dirt gets into the tank or the supply lines.

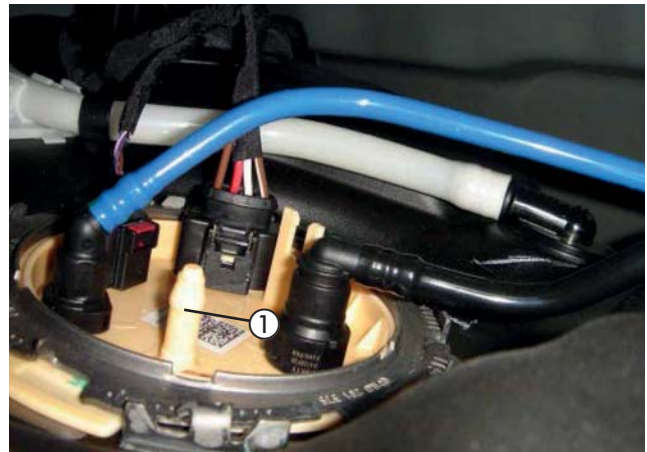

Fig. 36

- ① Connection socket at the tank fitting

Take the fuel pipe (intake line) through the connection socket into the tank and push the 7.5/3.5 mm  $\emptyset$  adapter onto the connection socket.

Fasten the adapter with the 11 mm  $\emptyset$  clip.

Take the fuel pipe to the installation position of the metering pump on the right-hand underside of the vehicle behind the tank.

Mount the tank again.

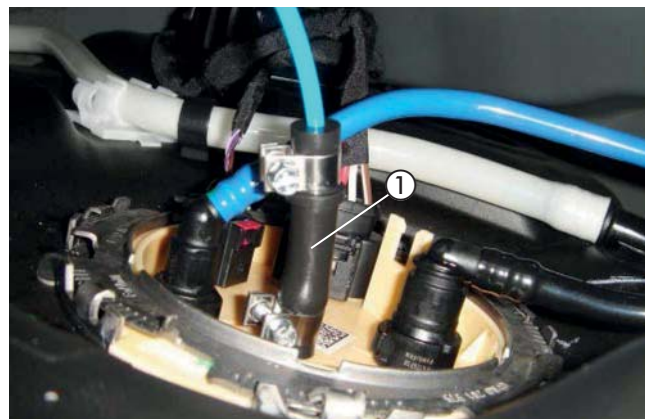

Fig. 37

- ① Fuel pipe connected with adapter

#### PLEASE NOTE!

Secure all connection points with clamps.

### 3 INSTALLATION

#### LAYING THE FUEL PIPE

(see Figs. 38 to 40)

Mount the fuel pipe (delivery line) to the fuel connection of the heater with the 4.5/3.5 mm Ø adapter.

Plug in the connector of the main cable harness, the water pump cable loom and the power supply cable loom to the heater.

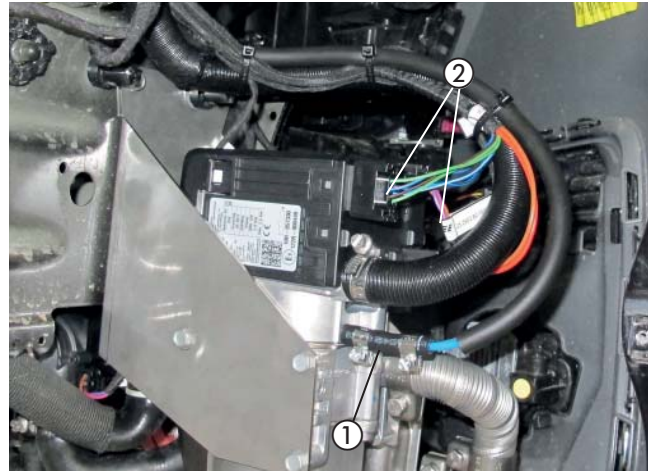

Fig. 38

- ① Fuel pipe (delivery line) mounted with adapter
- ② Electrical connections plugged in at heater

Route the fuel pipe (delivery line) together with the metering pump cable to the right side of the vehicle.

Push the heat protection tube onto the metering pump cable in the area of the particulate filter.



Fig. 39

- ① Heat protection tube pushed onto the metering pump cable

Take the fuel pipe (delivery line) together with the metering pump cable along the vehicle's cable loom to the installation position of the metering pump at the right-hand vehicle underbody.

#### CAUTION!

When laying fuel lines, always ensure they are at an adequate distance from hot vehicle and heater parts.

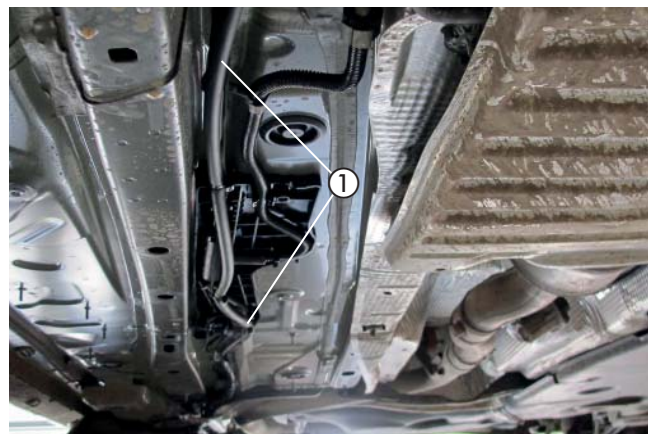

Fig. 40

- ① Fuel pipe (delivery line) and metering pump cable routed



### 3 INSTALLATION

#### INSTALL AND CONNECT THE METERING PUMP

(see Fig. 41)

Mount the premounted metering pump to the rear right-hand tank fastening with an M8 screw.

Ensure it is installed with at least a 15° rising gradient on the pressure side. The discharge end of the metering pump points to the left.

Connect the fuel pipe (intake line) with the 3.5 x 3 mm Ø fuel hose to the intake connection of the metering pump.

Connect the fuel pipe (delivery line) from the heater to the 3.5 x 3 mm Ø fuel hose at the discharge end of the metering pump.

Slot the plug-in contacts of the metering pump cable into the mating connector regardless of polarity. Connect the connector to the metering pump.

#### CAUTION!

Use a sharp knife to cut the fuel pipe to length.

Secure all hose connections with hose clips.

When laying fuel lines, always ensure they are at an adequate distance from hot vehicle and heater parts.

#### MOUNT FUSE HOLDER

(see Fig. 42 to 44)

Drill open the existing hole in the left-hand wing bracket to 9 mm Ø and insert an M6 blind rivet nut.



Fig. 41

① Metering pump installed and connected

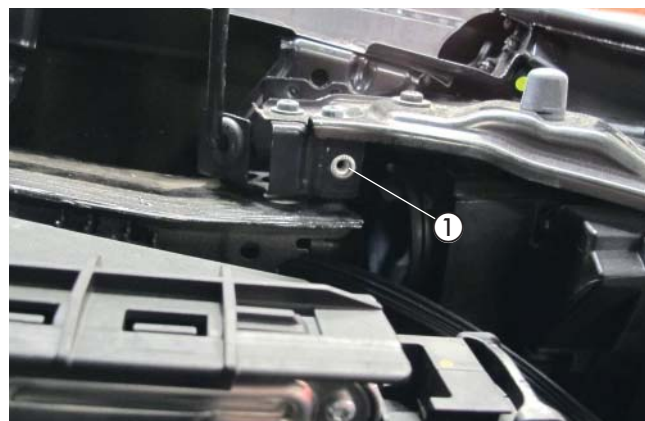
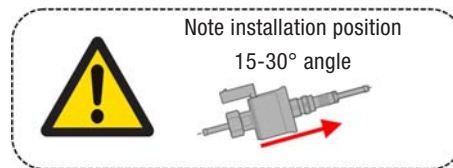

Fig. 42

① Blind rivet nut M6 mounted

### 3 INSTALLATION

Fasten 90° angle bracket to the M6 blind rivet nut using an M6 x 16 screw and align as shown.



Fig. 43  
① 90° angle bracket mounted

Mount the premounted bracket with the fuse block holder to the 90° angle bracket using an M6 x 12 screw and an M6 nut.

Align the fuse holder downwards slightly so that the bonnet bracket does not touch the fuse block holder.



Fig. 44  
① Fuse block holder mounted to 90° angle bracket

#### CABLE LAYING (see Fig. 45)

Take the vehicle interior cable loom consisting of:

- 4 mm<sup>2</sup> white/red and 0.5 mm<sup>2</sup> black/red cable
- 3-wire control unit cable loom
- 4-pin fan control box cable loom

through the cable grommet on the left-hand side of the engine partition and into the interior of the vehicle.

#### **⚠ CAUTION!**

When laying the cable looms, ensure they are at an adequate distance from hot vehicle and heater parts.

Use cable ties to fix the cable looms in suitable places.

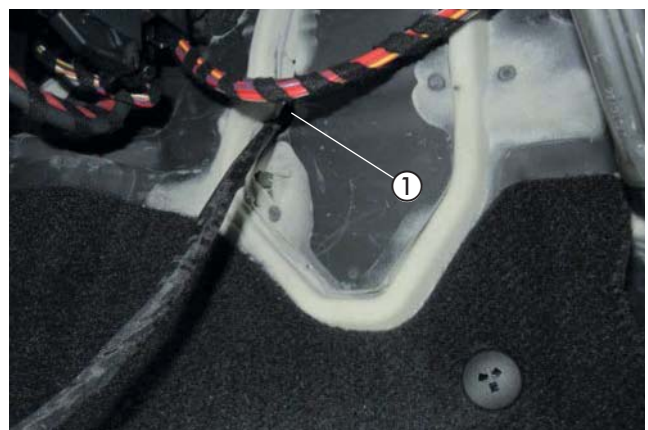

Fig. 45  
① Engine partition cable grommet

### 3 INSTALLATION

#### FAN CONTROL

(see Figs. 46 to 49)

Mount the Smart IPCU block and the 1 mm<sup>2</sup> brown earth cable with an M6 x 12 screw to the existing hole in the supporting strut of the centre console on the passenger side.

Insulate the 1 mm<sup>2</sup> red/ white cable from the Smart IPCU cable loom and tie it back.

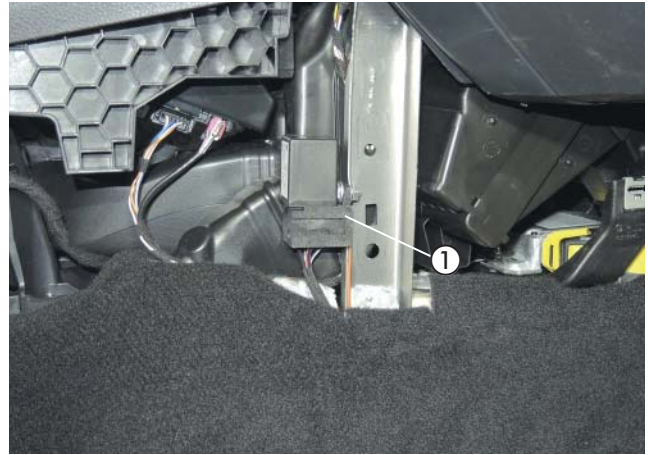

Fig. 46

① IPCU module base mounted

Disconnect the 0.5 mm<sup>2</sup> violet/white cable (pin 4) at the 4-pin black connector of the fan motor and integrate the 1 mm<sup>2</sup> black and 1 mm<sup>2</sup> black/white cables using two (red) butt-type connectors as shown in the circuit diagram.

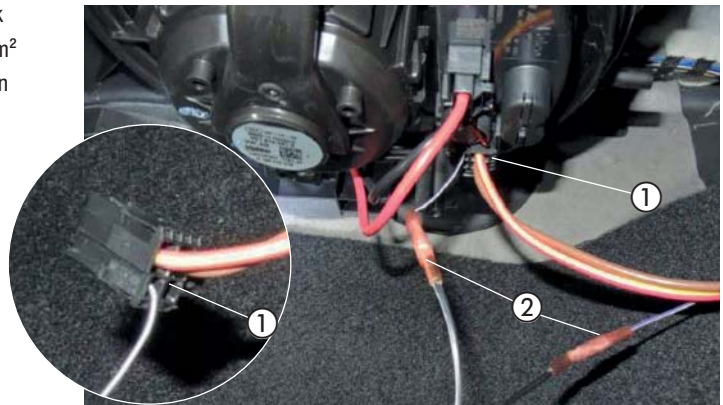

Fig. 47

① 4-pin connector fan motor

② Cutting point 0.5 mm<sup>2</sup> violet/white cable

Connect the 0.5 mm<sup>2</sup> black/red cable from the connector block of the IPCU module with the 0.5 mm<sup>2</sup> black/red cable from the control unit cable loom using a (red) butt-type connector.

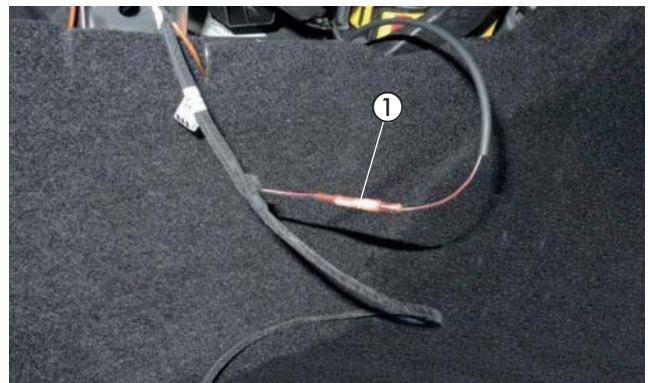

Fig. 48

① 0.5 mm<sup>2</sup> black/ red cable connected

**PLEASE NOTE!**  
The cable colours may vary.

### 3 INSTALLATION

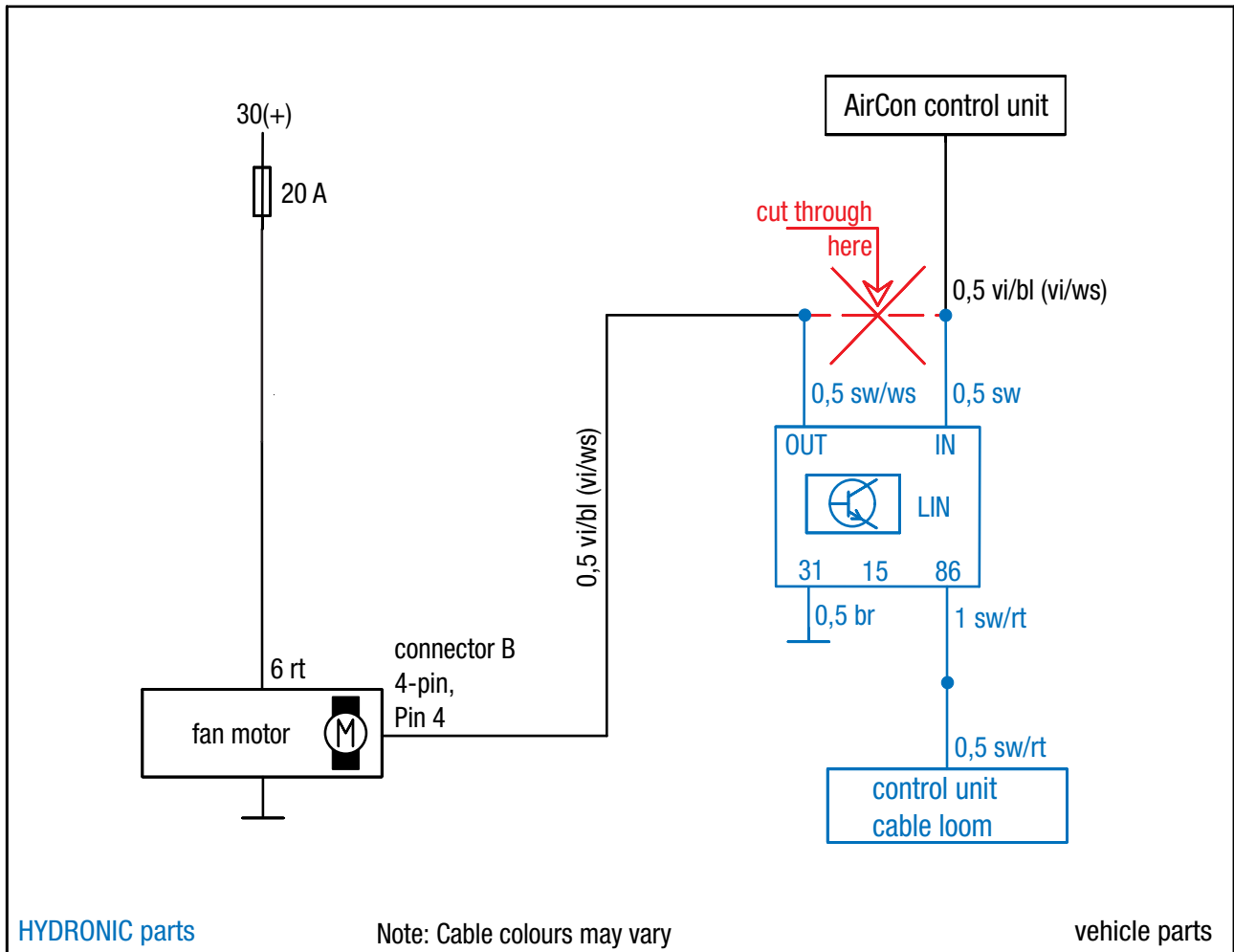

Fig. 49

#### CABLE COLOURS

rt	red	or	orange
sw	black	vi	violet
bn	brown	ge	yellow
ws	white	ro	pink
bl	blue	gr	grey
gn	green		

#### CABLE COLOURS

RD	red	OR	orange
BK	black	VT	violet
BN	brown	YE	yellow
WH	white	PK	pink
BU	blue	GY	grey
GN	green		



## 3 INSTALLATION

### SMART IPCU – PROCEDURE FOR TEACHING THE MODULE

1. Switch ignition on
2. Adjust heater fan to the fan strength required for pre-heater mode at the heater control unit.
3. Switch heater on (water outlet temperature >30°C) – LED lights up
4. Teach module – Press button briefly once – LED flashes quickly

#### A: PWM signal or analogue voltage (voltage divider):

- If the signal is successfully detected,
  - the relevant fan control signal is saved in the IPCU.
- The IPCU is ready as soon as the LED goes off again.
- Teaching is finished.

#### B: LIN bus signal:

- If the signal is successfully detected,
  - the relevant fan control signal is saved in the IPCU.
- LED flashes in the rhythm 3x short – pause – 3x short – pause etc.
- Vehicle ignition “OFF”
- The IPCU is ready as soon as the LED goes off again.
- Teaching is finished.



#### Possible LED displays

LED display	Function
on constantly	module not taught
flashes slowly	module in teaching/analysis mode
flashes every second	Fan control
flashes 1x every 5 sec	module ready

#### TO CHANGE A SAVED FAN SETTING IN THE SMART IPCU:

1. Press and hold the button on the top of the IPCU housing (> 15 sec).
2. This restores the IPCU to the factory settings and teaching can begin again. The LED in the IPCU is on constantly.

## 3 INSTALLATION

### INSTALL CONTROL UNIT

(see Figs. 50 to 53)

#### Mountin EasyStart Timer

The EasyStart Timer installed according to the Technical Description for the EasyStart Timer, refer to the “Installation Instructions” section.

Mount the EasyStart Timer in the trim moulding of the instrument panel on the left next to the steering column.

(Alternative suggestion - consult with the customer)



Fig. 50

① EasyStart Timer mounted

#### Mountin EasyStart Remote/Remote+ and Web

The EasyStart Remote/Remote+ is installed according to the Technical Description for the EasyStart Remote/Remote+ Radio Remote Control or Technical Description for the EasyStart Web; refer to the “Installation Instructions” section.

Mount the button for the EasyStart Remote/Remote+/Web in the trim moulding of the instrument panel on the left next to the steering column, using the dimensions shown.

To do so, drill a 10 mm Ø hole and insert the button in the hole.

(Alternative suggestion - consult with the customer)



Fig. 51

① Control unit button mounted

#### OPTIONAL:

Attach the temperature sensor to the lower trim moulding of the A-pillar on the passenger side as shown.



Fig. 52

① Temperature sensor mounted

### 3 INSTALLATION

Using an M4 x 10 screw and two B5 body washers, fasten the stationary part of the control unit to the existing hole on the left in the bracket of the instrument panel.

Connect the antenna cable of the EasyStart Remote/Remote+ to the stationary part, take it to the right and lay it in the rubber door seal on the passenger's side.

Lay the cables from the installed button and temperature sensor together with the "Control unit" cable loom to the installation site of the stationary part and connect here.



#### CAUTION!

Use cable ties to fix any excessive length of antenna cable underneath the instrument panel.

#### POWER SUPPLY

(see Fig. 54)

Lay the 4 mm<sup>2</sup> red positive cable up to the battery and connect to the battery terminal with the A6 cable lug.

Fasten the 2.5 mm<sup>2</sup> brown earth cable to the earthing point of the engine partition with the existing M6 nut.



Fig. 53

① Stationary part mounted



Fig. 54

① 4 mm<sup>2</sup> red positive cable connected

② 2.5 mm<sup>2</sup> brown earth cable connected

## 4 FOLLOWING INSTALLATION

### MOUNT EXHAUST GROMMET

(see Figs. 55 and 56)

Drill a 38 mm  $\varnothing$  hole on the right-hand side of the sub-cowling with the dimensions as shown.

Insert the 41 mm  $\varnothing$  exhaust grommet in the drilled hole.



Fig. 55

① Exhaust grommet installed

Mount the sub-cowling and take the exhaust pipe end through the grommet

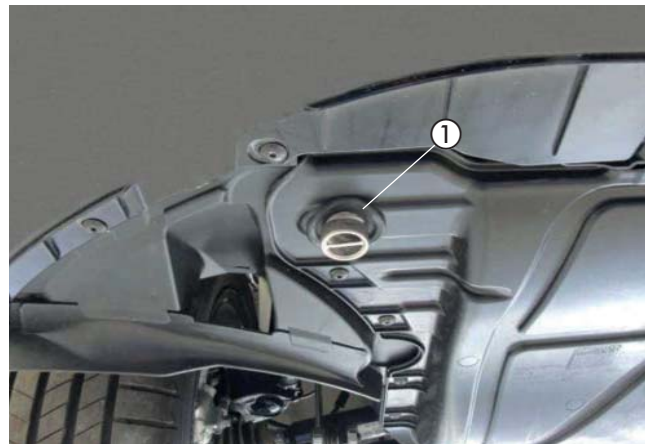

Fig. 56

① Exhaust pipe end passed through the exhaust grommet

### FIT DUPLICATE NAMEPLATE

(see Fig. 57)

Adhere the duplicate nameplate to the B-pillar.



Fig. 57

① Exhaust pipe end passed through the exhaust grommet

## 4 FOLLOWING INSTALLATION

### ADHERE THE “REFUEL” LABEL

(see Fig. 58)

Adhere the “Refuel” label inside the fuel tank flap as shown.



Fig. 58

① Exhaust pipe end passed through the exhaust grommet

### COMPLETE THE VEHICLE

- Install all removed parts in the reverse order.
- Reconnect the battery.
- Check that the hoses, hose clips and pipe clamps as well as all electrical connections are fitted securely.
- Use cable ties to secure all loose cables, lines, etc.
- Restore all the vehicle's programmed settings (radio, window lift, etc.).
- Fill the cooling system, start the engine, vent the cooling system and check for leaks, top up any missing coolant liquid.
- Adhere the duplicate nameplate in a clearly visible position near the heater or at a suitable point on the B-pillar.
- Adhere the “Refuel” label in the fuel tank flap or at a suitable point on the B-pillar.
- Please also note and follow the vehicle manufacturer's information on filling and venting the cooling system.
- Read and observe all official regulations and safety instructions in the Technical Description.
- Program the control unit and place the operating instructions in the glove compartment.
- Place the leaflet for the customer in the glove compartment or hand over personally to the customer.



### CAUTION!

Fill the cooling system only with the coolant liquid specified by the vehicle manufacturer.

### STARTING UP THE HEATER

- Switch on the heater at the control unit.  
See Operating Instructions - Control.





## LEAFLET FOR THE CUSTOMER

### BEFORE SWITCHING ON IN VEHICLES WITH 2-ZONE AUTOMATIC AIRCON

- Before switching on or pre-programming the heating mode with the ignition switched on, set the vehicle's temperature controllers ① to maximum setting (HI).
- Adjust the air flow ② to maximum air flow to the windscreen.
- The fan speed does not need to be pre-selected.



- ① Button for the temperature setting
- ② Adjusting the airflow

#### PLEASE NOTE!

- Switch the pre-heater on at least once a month for about 10 minutes, also in the summer months! This will ensure that it works properly during the season!
- We recommend adjusting the heating time to the driving time: Driving time > heating time.

#### PLEASE NOTE!

In vehicles with interior monitoring, this must be disabled for the heating process. Please refer to the vehicle operating instructions for disabling instructions.

**Headquarters:**

Eberspächer Climate Control Systems GmbH & Co. KG

Eberspächerstraße 24

73730 Esslingen

Hotline: 03976 2350 235

Fax hotline: 01805 262624

[info@eberspaecher.com](mailto:info@eberspaecher.com)

[www.eberspaecher.com](http://www.eberspaecher.com)

