

Bumpers - Front Bumper Cover[Print](#) [Report An Error](#)**Removal and Installation****Removal**

NOTE: Removal steps in this procedure may contain installation details.

All vehicles

1. Refer to: [Supplemental Restraint System \(SRS\) and Pedestrian Protection System Depowering](#) (501-20B Supplemental Restraint System, General Procedures).
2. Refer to: [Jacking and Lifting](#) (100-02 Jacking and Lifting, Description and Operation).

Vehicles equipped with V8 performance package

3.

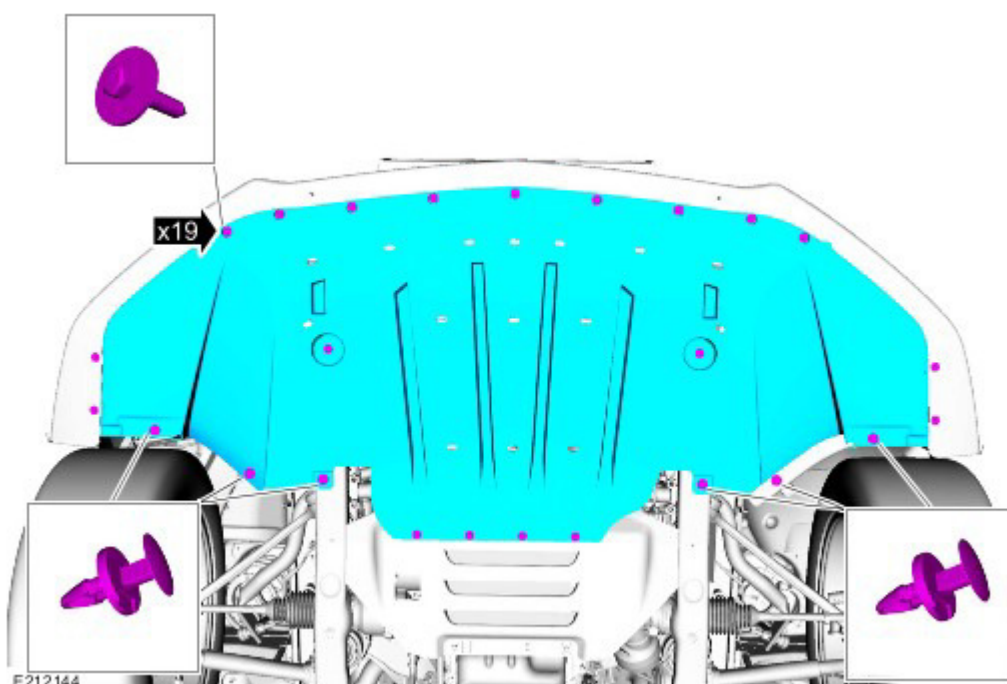

Vehicles not equipped with V8 performance package

4.

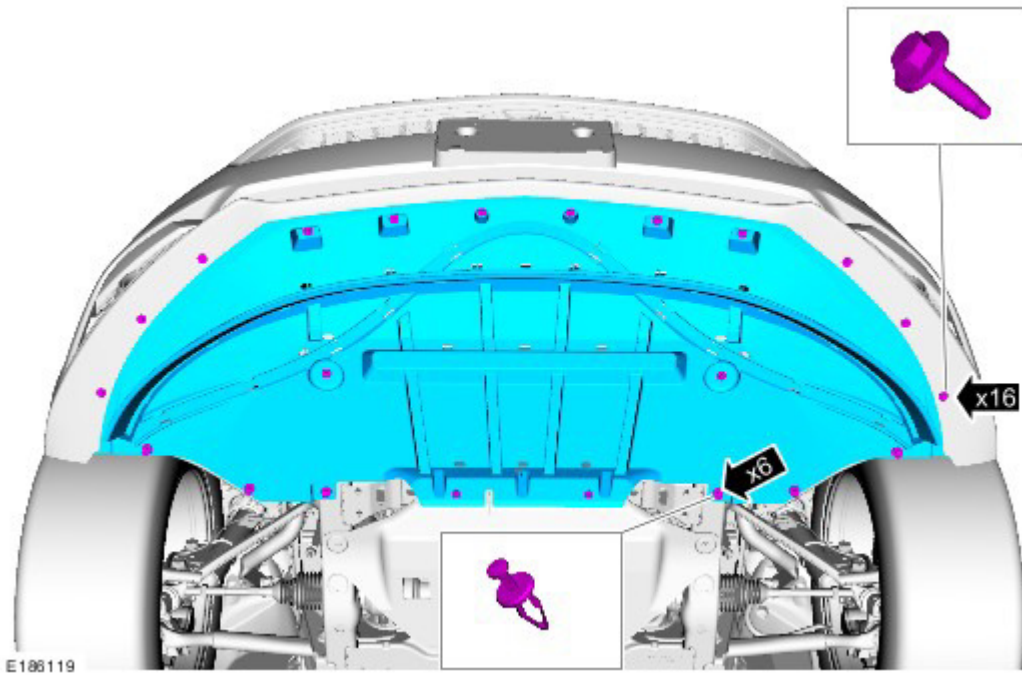

All vehicles

5. NOTE: On both sides.

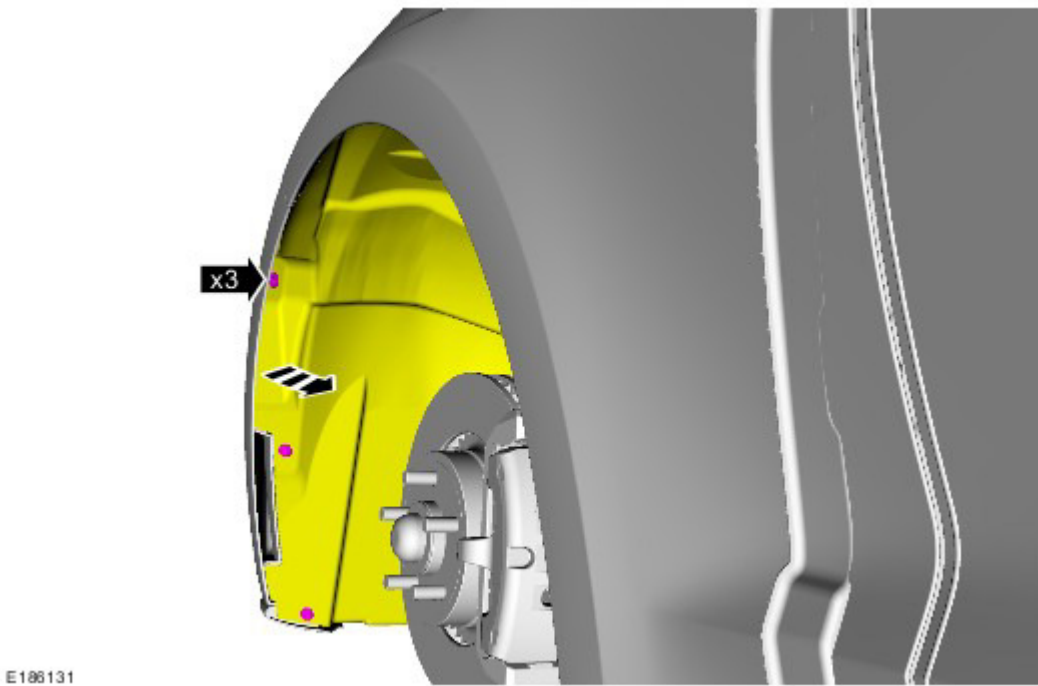

6. NOTE: On both sides.

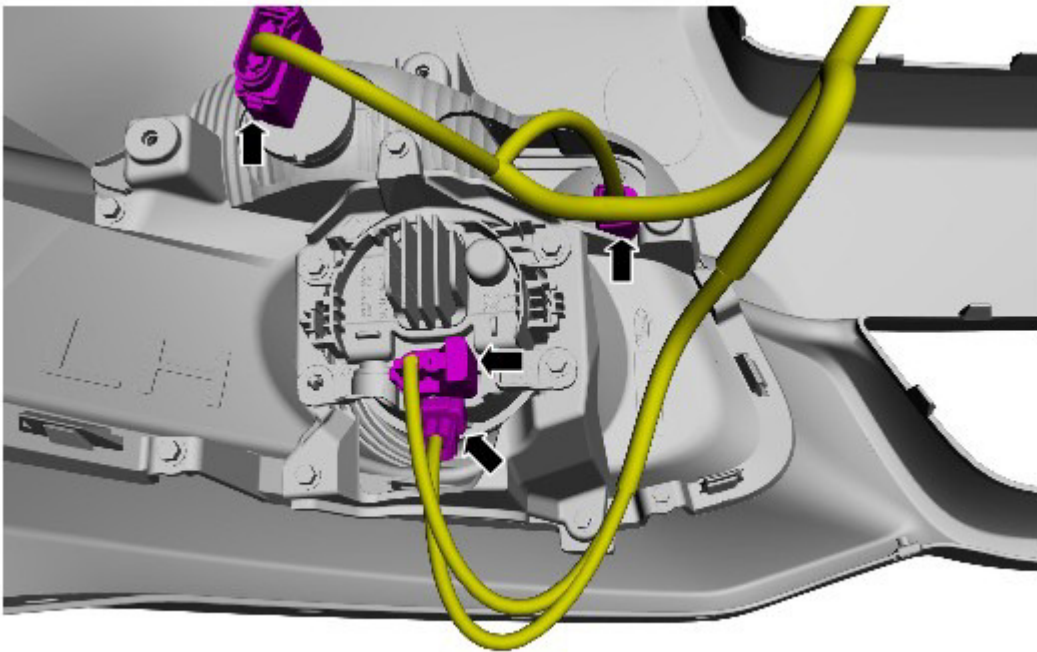

E224322

7.

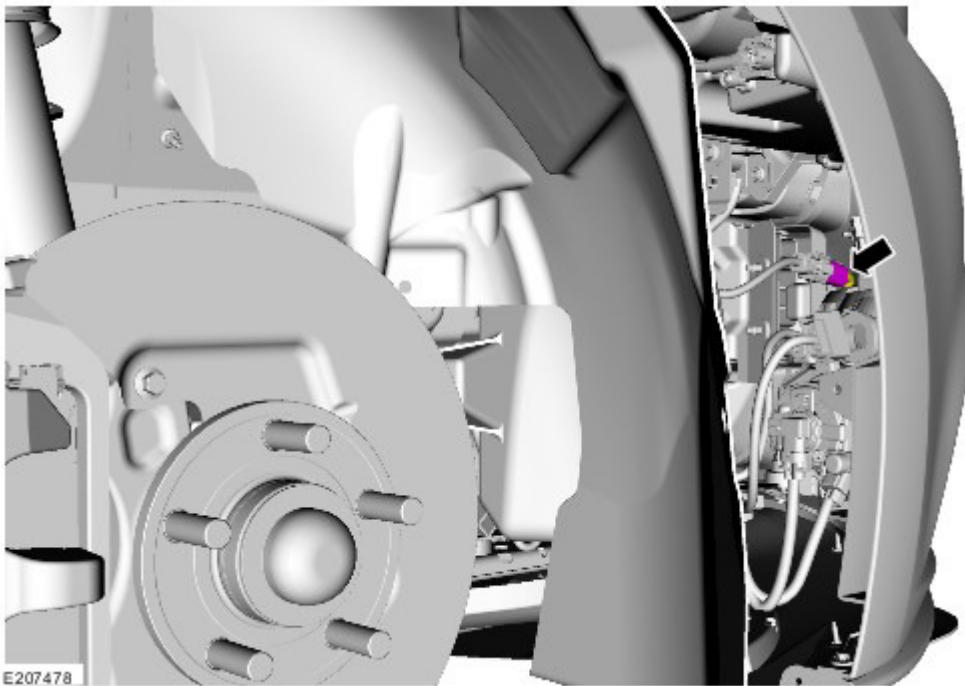

E207478

8. NOTE: On both sides.

Torque: 1.7 Nm

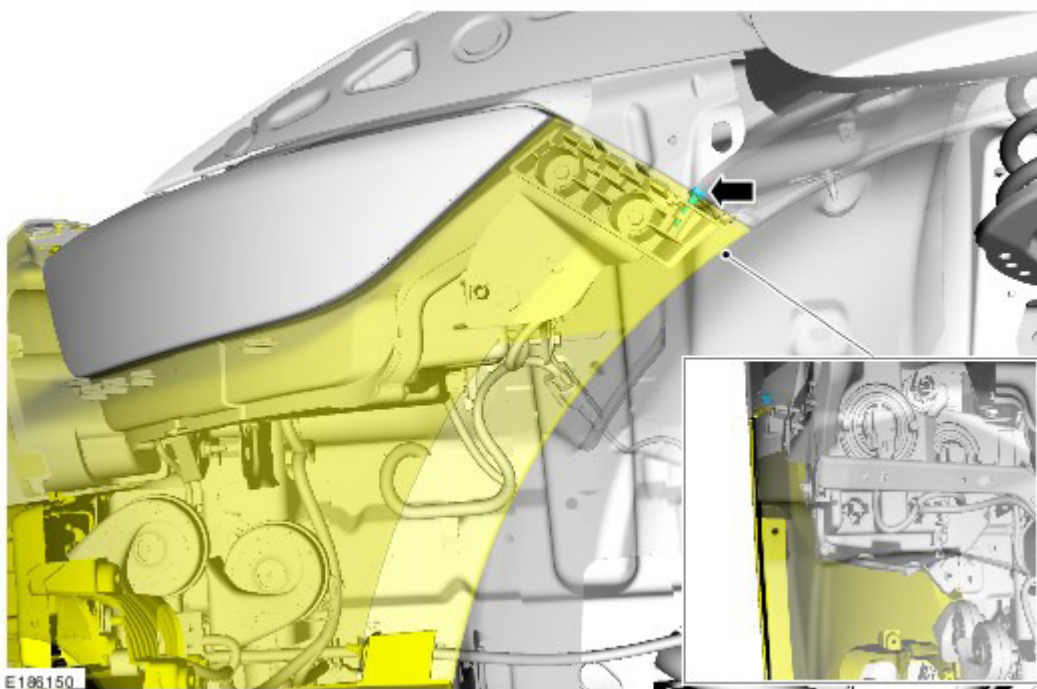

9.

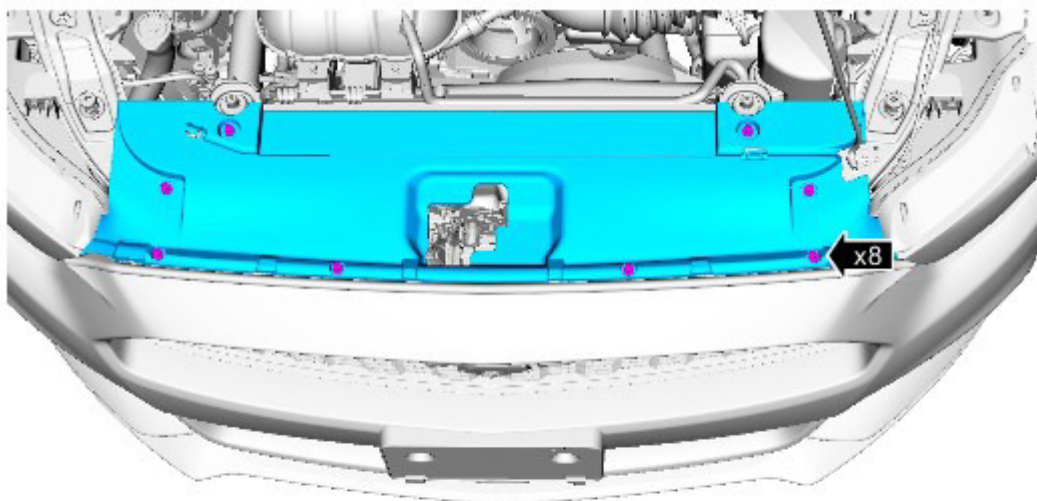

E188154

10. NOTE: On both sides.
Torque: 1.7 Nm

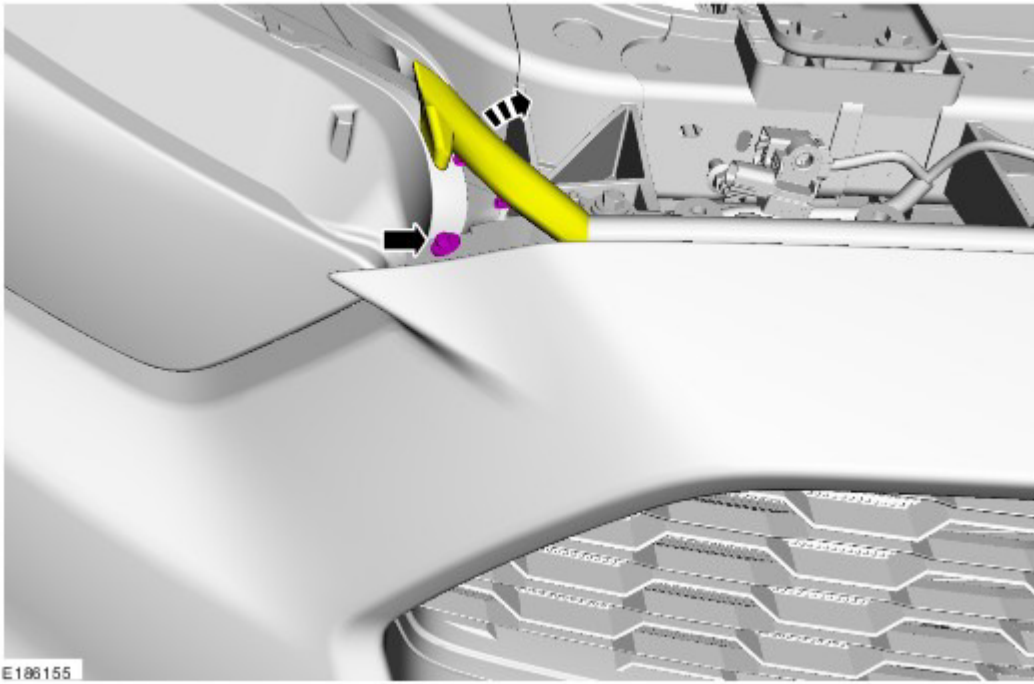

11. Torque: 5.4 Nm

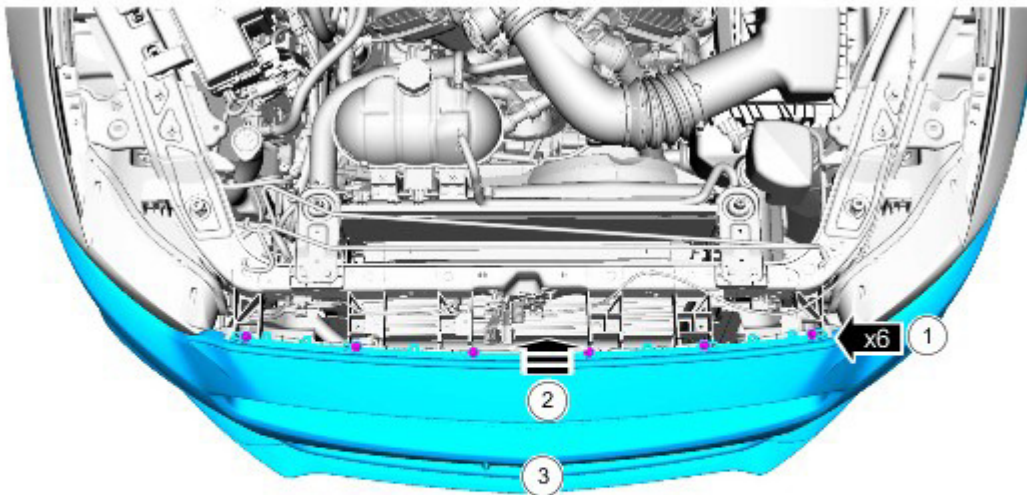

E186157

12.

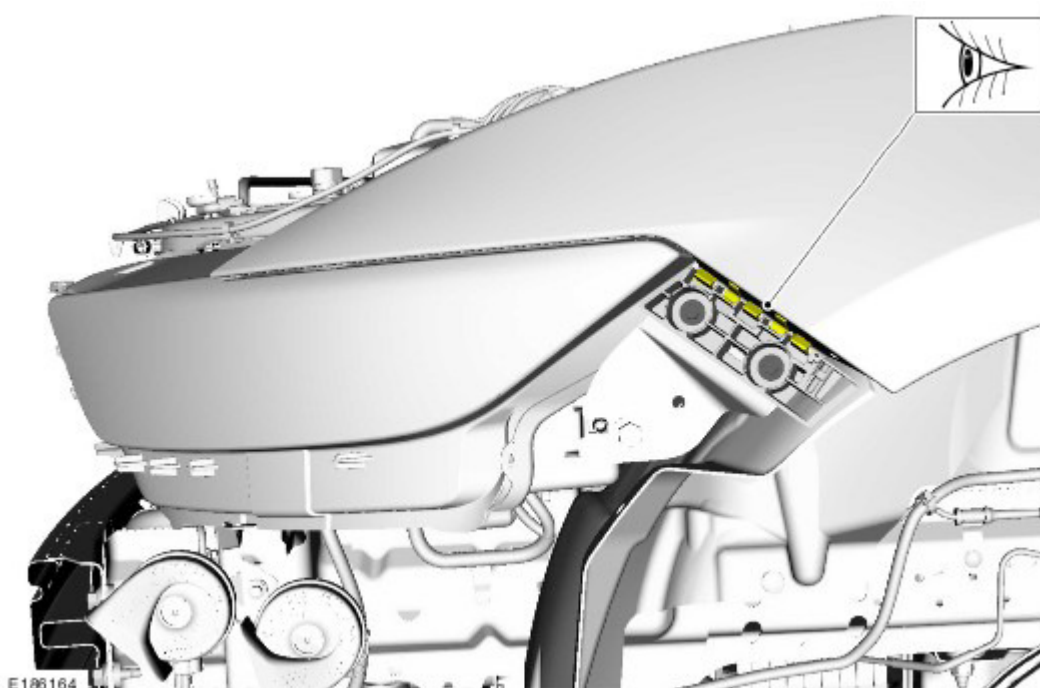

13. This step is only necessary when installing a new component.

Torque: 1.5 Nm

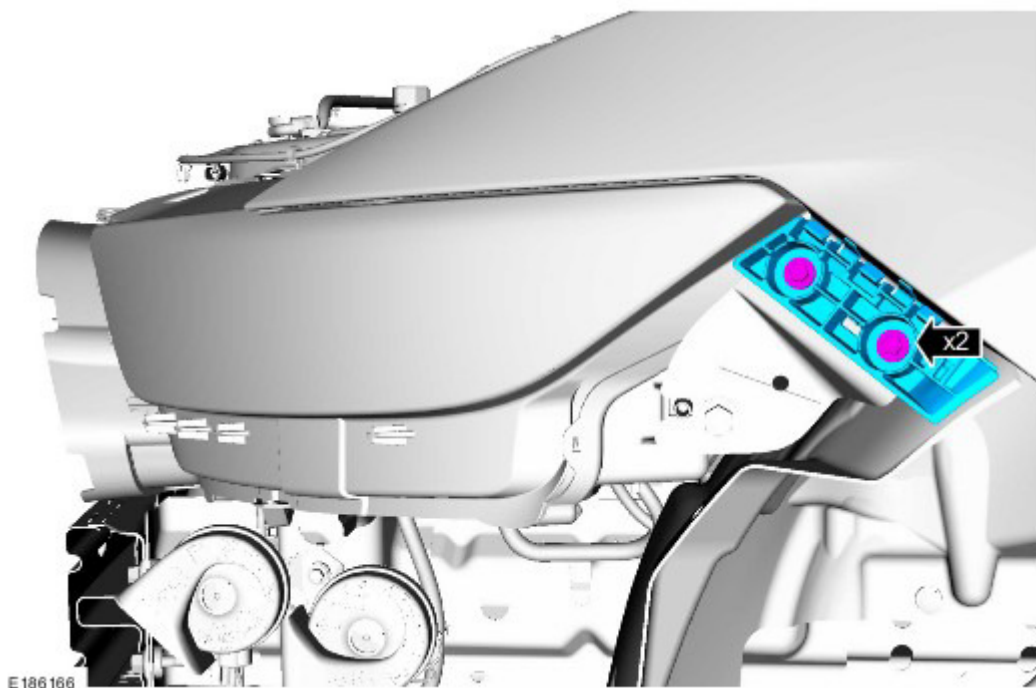

Installation

1. To install, reverse the removal procedure.
2. Refer to: [Supplemental Restraint System \(SRS\) and Pedestrian Protection System Repowering](#) (501-20B Supplemental Restraint System, General Procedures).